

The IMT actuators are developed for application requiring linear movements and positioning to a high degree of accuracy, repeatability and speed variations in synchronised system.

They are made with a ball screw, which is rotated by an electric motor, and a ball nut driving the external piston for the ISO 15552 cylinder.

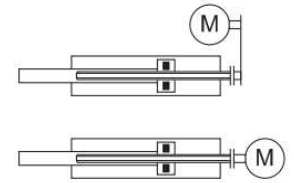

Heads	7075 aluminum with anodized finish
Piston Rod	Chrome Plated Steel
Barrel	Anodized profiled aluminum tube
Seals	Polyurethane
Temperature Range	(-10° & +80°)
Standard	according to ISO15552

Standard Strokes	Up to 1000 mm as standard, more on Request
Nominal Cylinder Force	45000 N
Max. Speed	333 mm/sec Δ 2000 rpm
Ball Screw	50 x 10 mm
Ball Screw Capacity	Static 77,5 KN Dynamic 54,3 KN
Motor Type	Servo or Stepper

Degree of protection to IEC 60529	IP54
Duty cycle [%]	100
Max. acceleration	8 [m/s ²]
Max. rotational speed	3500 RPM
Repetition accuracy	±0.03 mm

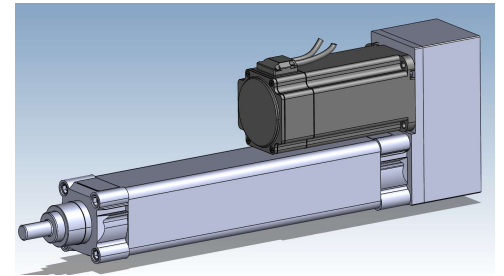

Other Options

- Extended Rod
- Special Piston rod thread
- IP65
- Stainless Steel Piston Rod
- Internal Linear Encoder SSI

Suitable for all Pneumatic Cylinder mounting Equipment.

Piston rod protected against rotation (up to 600mm) with plain-bearing guide

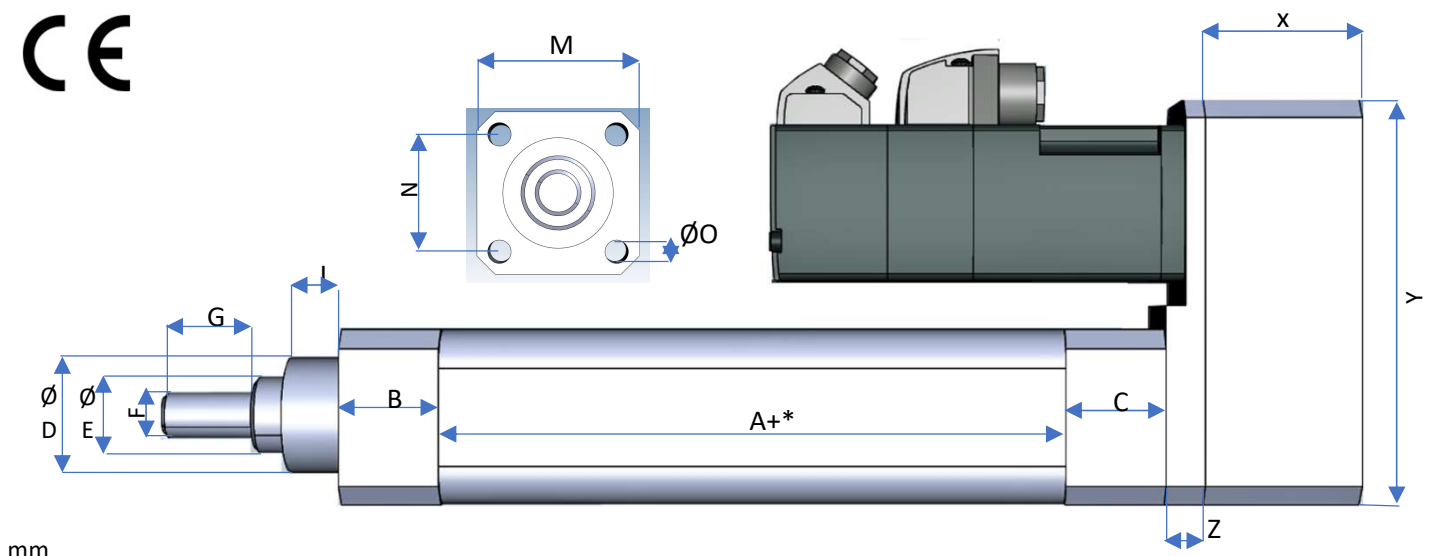

mm

A	B	C	ØD	ØE	F	G	I	M	N	Z	X**	ØO
200	75	75	100	70	M36x2	72	30	140	110	24	100	M12

* Stroke

** X,Y,Z Varies depending on the selected Motor